

LINSEIS

pushing boundaries

**HCS L36 BASIC/
ADVANCED/ULTIMATE**

Hall-Effect
**Characterization
System**



WWW.LINSEIS.COM



Since 1957 LINSEIS Corporation has been delivering outstanding service, know-how and leading innovative products in the field of thermal analysis and thermo-physical properties.

Customer satisfaction, innovation, flexibility, and high quality are what LINSEIS represents. Thanks to these fundamentals, our company enjoys an exceptional reputation among the leading scientific and industrial organizations. LINSEIS has been offering highly innovative benchmark products for many years.

The LINSEIS business unit of thermal analysis is involved in the complete range of thermoanalytical equipment for R&D as well as quality control. We support applications in sectors such as polymers, chemical industry, inorganic building materials, and environmental analytics. In addition, thermophysical properties of solids, liquids, and melts can be analyzed.

Rooted in a strong family tradition, LINSEIS is proudly steered into its third generation, maintaining its core values and commitment to excellence, which have been passed down through the family leadership. This generational continuity strengthens our dedication to innovation and quality, embodying the essence of a true family-run business.

LINSEIS provides technological leadership. We develop and manufacture thermoanalytic and thermophysical testing equipment to the highest standards and precision. Due to our innovative drive and precision, we are a leading manufacturer of thermal analysis equipment.

The development of thermoanalytical testing machines requires significant research and a high degree of precision. LINSEIS Corp. invests in this research to the benefit of our customers.

C L A U S L I N S E I S
C E O D I P L . P H Y S .



To strive for the best due diligence and accountability is part of our DNA. Our history is affected by German engineering and strict quality control.

We want to deliver the latest and best technology for our customers. LINSEIS continues to innovate and enhance our existing thermal analyzers. Our goal is to constantly develop new technologies to enable continued discovery in Science.



Engineering & Innovation

Linseis Service



Customized Solutions - The Linseis Advantage

At Linseis, we believe that every measurement challenge is unique — and so should be your instrument.

While many suppliers rely on standardized configurations, Linseis distinguishes itself through exceptional flexibility and the capability to deliver customer-specific adaptations in record time.

Our experienced engineering teams work hand in hand with you to design and implement fully customized solutions that meet your precise application requirements — whether that means a unique sensor configuration, an extended temperature range, or a specialized software integration.

With decades of experience and a modular product architecture, we turn customization into a standard service — fast, efficient, and reliable.

Choose Linseis and experience what true flexibility in thermal analysis and material characterization means.

Contact form





Service & Support

Redefining Ownership

When investing in analytical instrumentation, long-term value matters just as much as precision. That's why Linseis systems are engineered to deliver the lowest **Total Cost of Ownership** in their class — combining reliability, efficiency, and flexibility in every detail.

Our instruments are built with robust, high-quality components designed for longevity and minimal maintenance. This means fewer service interventions, shorter downtimes, and reduced operating costs over the entire product lifetime. Intelligent software updates and remote support further ensure that your system remains state-of-the-art, even years after installation.



Hall-Effect Characterization System

The HCS System permits the characterization of semiconductor devices regarding their electric transport properties, in particular Hall-mobility, Charge Carrier Concentration, Resistivity and Seebeck Coefficient.

The integrated desktop setups offer a complimentary product line-up from a basic, manual operated, Hall Characterization stage to an auto-mized high temperature stage up to the innovative Halbach configuration for the characterization of most challenging samples.



HCS L36 Basic

Measurement features

- Charge Carrier Concentration (Sheet [$1/\text{cm}^2$]/ Bulk [$1/\text{cm}^3$])
- Hall-Mobility [cm^2/Vs]
- Sheet resistance [Ω]
- Resistivity [Ωcm]
- Conductivity [S/cm]
- Alpha (horizontal/vertical ration of resistance)
- Megneto resistance
- Seebeck Coefficient [$\mu\text{V}/\text{K}$]

The **HCS L36 Advanced** system uses a Halbach magnet with ± 0.5 T and offers both DC and AC modes. The Halbach-Magnet is a magnet array consisting of multiple permanent magnet segments. Due to the specific two-pole layout of the magnets, a magnetic field with very homogenous flux density is formed in the center.

By spinning the entire array around its own axis, the flow of flux density is $\sin(B)$ in the center, so it is alternating in a sinusoidal course.

In addition, the flux density in the center is amplified, whereas the flux density on the outside is relatively weak.

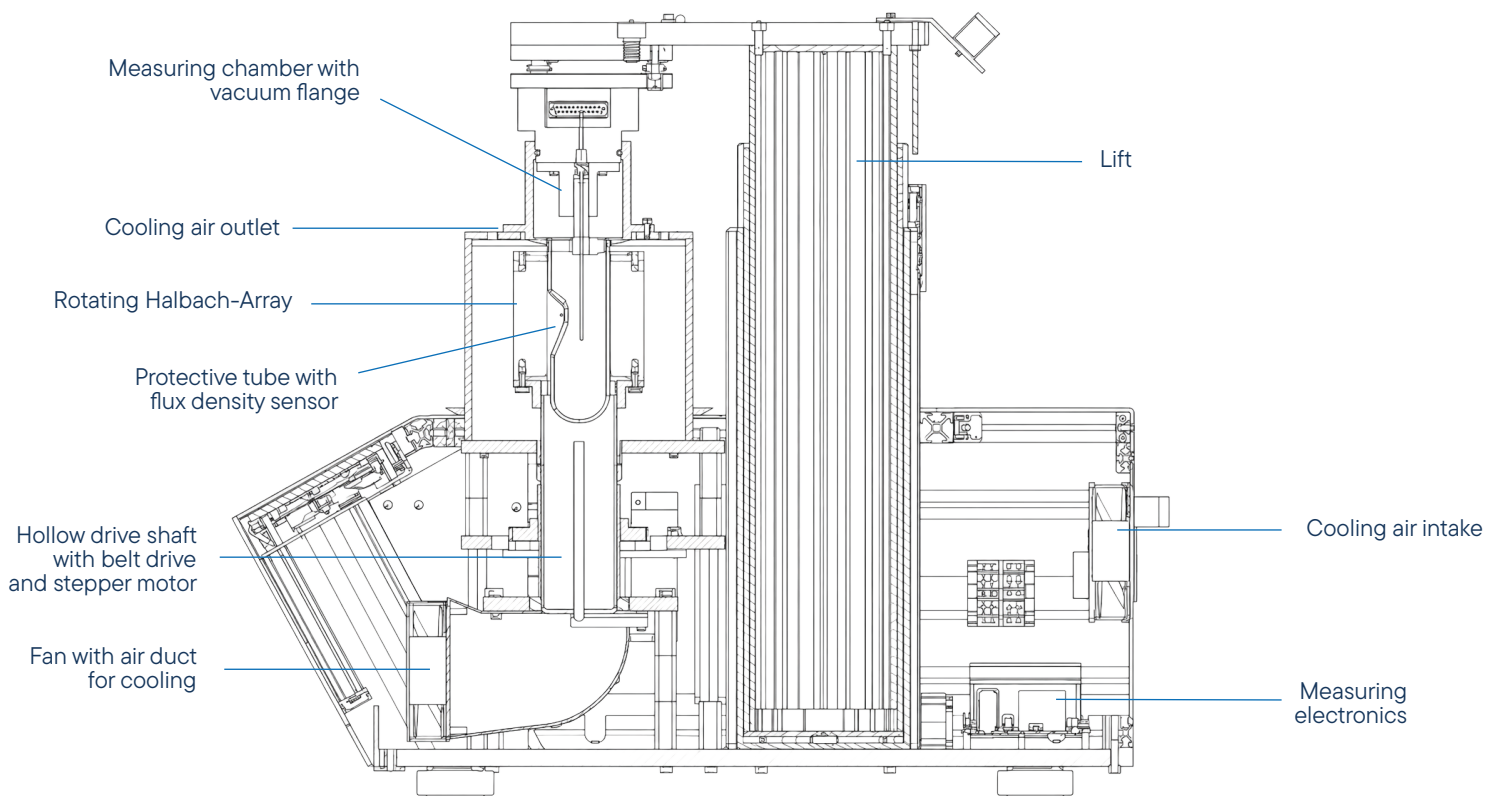

The systems can be equipped with different sample holder for various geometries and temperature requirements. An optional low temperature (LN2) attachments is available as well as a high temperature version up to 600 °C/800 °C, to ensure that all fields of application can be covered. Depending on the system configuration, either a permanent magnet, a water cooled electromagnet or a Halbach magnet provide magnetic field strength of up to 1 Tesla.

The comprehensive Windows based software offers an easy to use graphical user interface to control the system parameters, define measurement procedures and temperature profiles as well as allows for an easy data evaluation, presentation and storage.

Hall Constant

Mobility

High temperature

Easy handling

Charge carrier concentration

Seebeck coefficient option

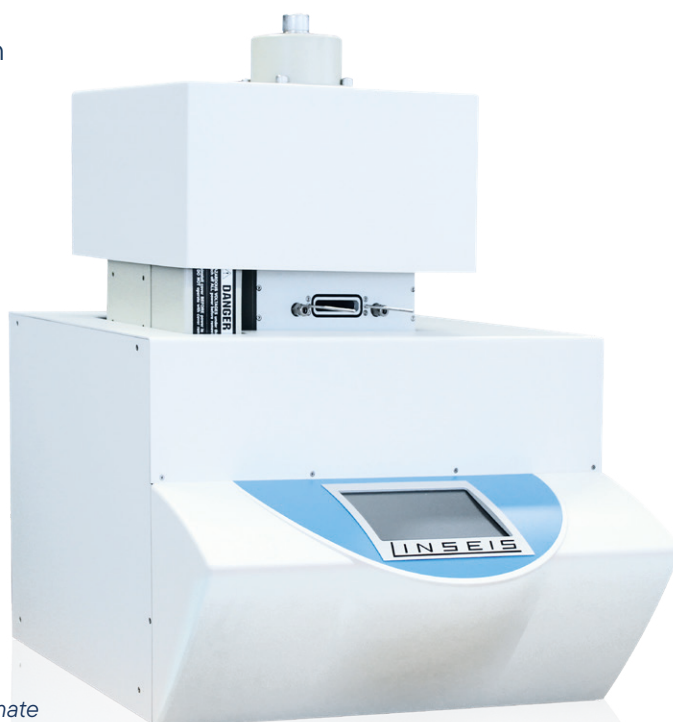

HCS L36 *Ultimate*

System features

- Gas tight measurement chamber which allows measurements under defined atmospheres or vacuum conditions
- 120 mm diameter magnets for highest field homogeneity and maximum accuracy as well as biggest measurable sample sizes
- Modular and upgradeable system design
- High temperature version up to 600 °C / 800 °C
- Lock-in amplifier upgrade for lowest noise measurements
- Connector for use of external electronics
- Integrated software package for easy handling
- Seebeck Coefficient option to apply on board temperature gradients up to 20 K

Sensors

The Linseis HCS systems are modular in design, so that the application areas can be easily expanded with a wide range of options. These include, for example, the Seebeck option, the gated hall bar setup and the illumination option. The plug-and-play system of the sample boards allows the measurement mode to be changed in a simple and fast way.

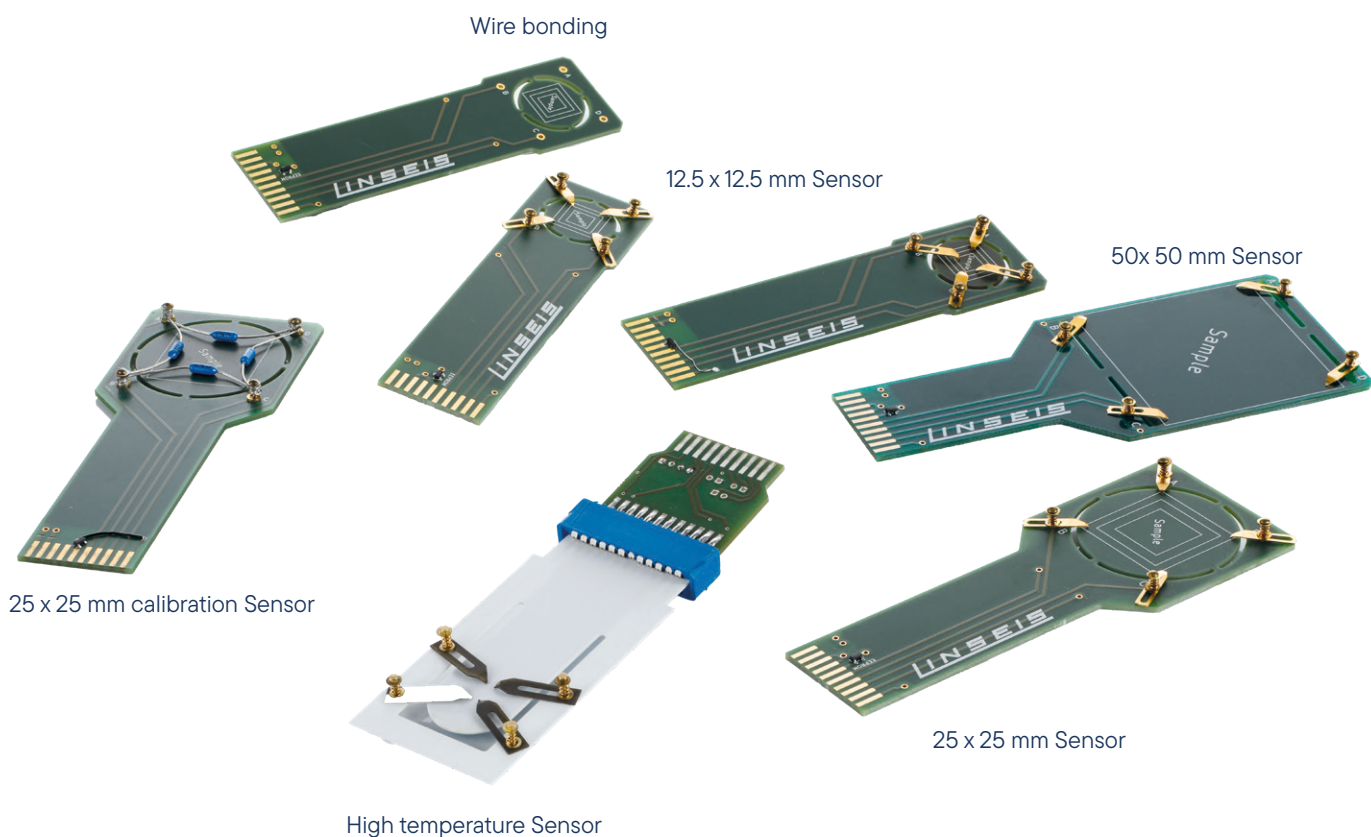

Exchangeable Sensors with an EPROM on it for easy plug and play usage.

Gated hall bar

The sample holder for Hall Bar or Gated Hall Bar measurements allow for example the characterization of nanowires and transistors. It can be used to determine the electrical conductivity, the Hall mobility and all quantities derived from those. Furthermore, it allows the investigation of the properties in dependence on an additional applied electric field, the gate. It should be noted that the structure of the sample, i.e. the contact scheme, in the gated Hall bar setup differs from the Van-der-Pauw setup and thus the sample must be prepared accordingly.

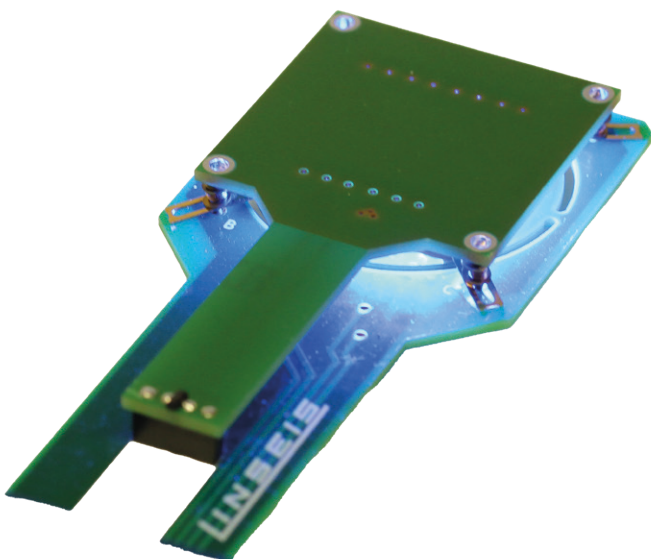
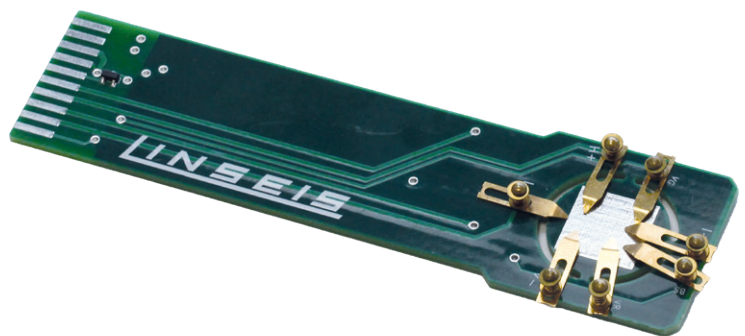

Illumination Option

The illumination option allows to perform Hall effect investigations under illumination of the sample. This allows effects to be analyzed by irradiation of different wavelengths in the blue, green and red range of light, and as a function of illuminance. This means that the additional sample holders can also be used to investigate the photoelectric effect. Consequently, this option is particularly interesting for example, for materials that are also used in photovoltaic systems.

Seebeck Option

	HCS L36 Basic	HCS L36 Ultimate
Sample Geometry	length: 6 to 20 mm width: 1 to 20 mm height: thinfilm up to 2 mm	length: 6 to 20 mm width: 1 to 20 mm height: thinfilm up to 2 mm
Seebeck Coefficient	-2500 $\mu\text{V/K}$ to 2500 $\mu\text{V/K}$	-2500 $\mu\text{V/K}$ to 2500 $\mu\text{V/K}$
Measurement	Slope technique: eliminates errors caused by temperature gradient offset or Seebeck voltage offset	Slope technique: eliminates errors caused by temperature gradient offset or Seebeck voltage offset
Gradient heater	temperature gradient up to ~ 10 K	temperature gradient up to ~ 10 K
Thermocouples	Type K	Type K

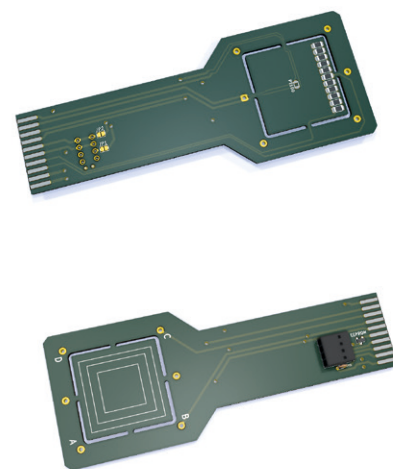

Measurement of the Constantan reference sample

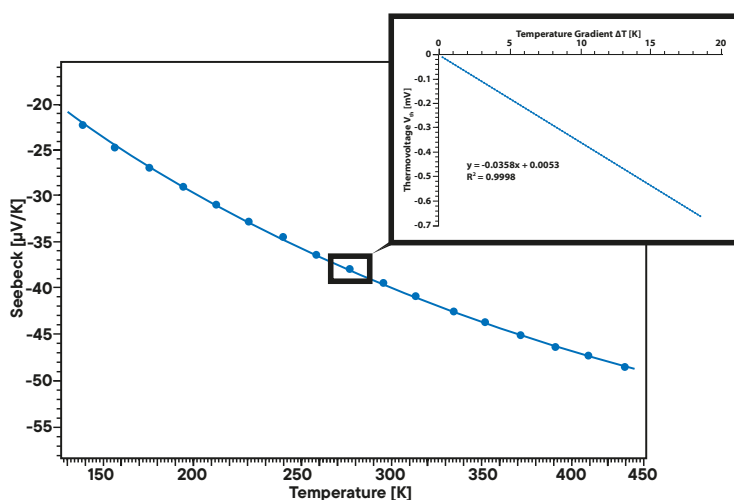

Seebeck Coefficient measurement on a Constantan reference sample from -140 °C up to $+180$ °C.

The Seebeck Coefficient is measured using the slope technique (see inset) for each temperature measurement point. The result can be plotted as Relative Seebeck Coefficient against Pt or as Absolute Seebeck Coefficient.

HCS Product Line

basic/ advanced/ ultimate

A wide variety of sample holders can be plugged into the sample holder socket (for different sample sizes and measurement types).

The chamber is vacuum-tight and allows measuring the sampler under defined atmospheres.

The **HCS L36 Basic** is equipped with two pairs of neodymium permanent magnets with a diameter of 120 mm. This allows for a very homogeneous magnetic field with a high flux density of at least 0.6T. The hall coefficient sample is measured with a DC excitation current. The bipolar current source allows to separation of the hall voltage from DC offsets such as thermovoltages.

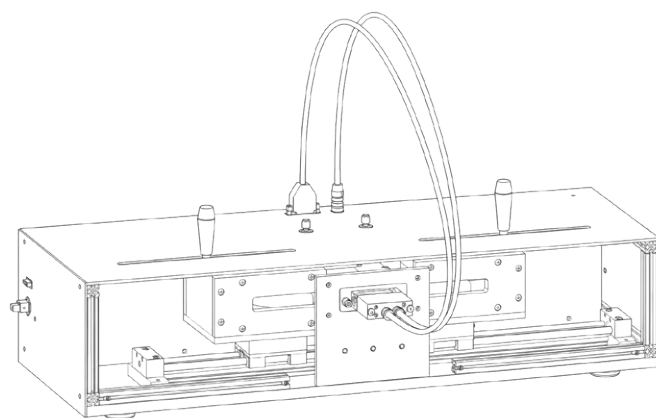

The **HCS L36 Advanced** system uses a Halbach magnet with ± 0.5 T and offers both DC and AC modes. While the DC mode is comparable to that of an HCS Basic, the AC mode, featuring a lock-in amplifier, enables precise measurements even with challenging samples (similar to the HCS Ultimate).

A flexible sample holder concept with plug-and-play interchange ensures easy sample installation. Samples up to $12.5 \times 12.5 \times 2$ mm³ can be measured in the range from room temperature to 600 °C.

Measurements are performed in a vacuum- and light-tight chamber with a variable atmosphere. Compact sample mounting boards are used for operation, particularly in the high-temperature range.

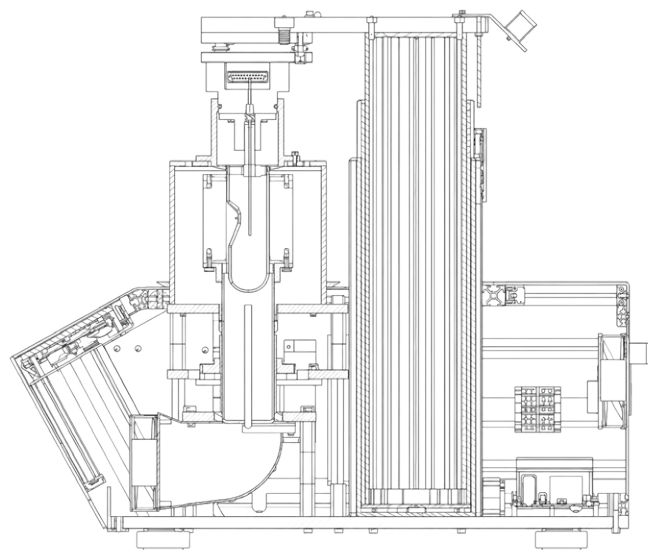

The **HCS L36 Ultimate** is equipped with a water-cooled electromagnet. That allows for measurements under a user-adjustable DC magnetic flux density range. The device is also available with an AC power supply for the electromagnet. The alternating magnetic field generates an alternating hall voltage when a DC excitation current is used. The misalignment voltage caused by sample asymmetry and thermovoltages is meaningless for the AC Amplitude measured.

The AC-share of the measured voltage consists only of the hall voltage and a voltage induced into the conductor loops. The AC signal is processed by a lock-in Amplifier with the flux density measured by a sensor to eliminate the 90 °C-out-of-phase induced voltage.

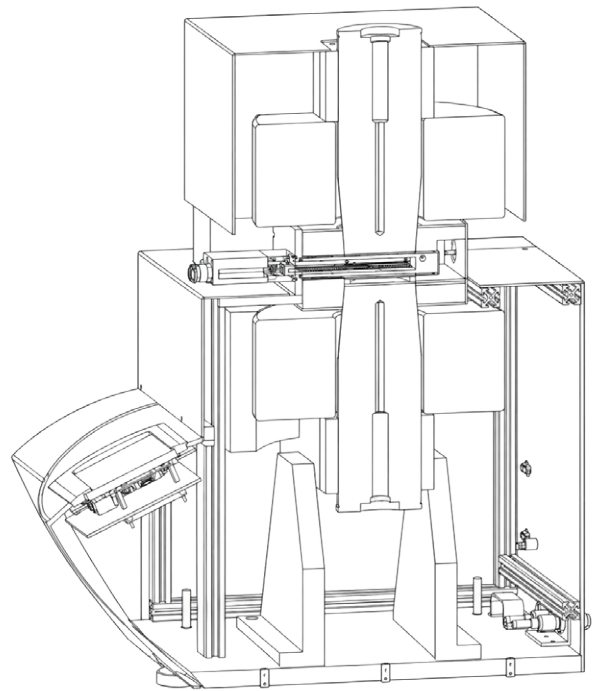

Software

All LINSEIS devices are PC controlled, where the individual software modules exclusively run under Microsoft® Windows® operating systems. The integrated software allows for an easy handling, temperature control, data acquisition and data evaluation.

LINSEIS

Hall effect measurement report

Parameters

Date:	Fri Nov 8 13:58:25 2019
Sample name:	ITO 200
Temperature:	80.02 °C
Res. current:	10 mA
Hall current:	10 mA
Thickness:	0.185 µm

Measurement data

AB [mV]	BC [mV]	AC [mV]	+MAC [mV]	-MAC [mV]
13.83	12.72	-1.109	-1.274	-0.9542
CD [mV]	DA [mV]	BD [mV]	+MBD [mV]	-MBD [mV]
13.82	12.71	1.111	0.9547	1.275

Results

Sheet resistance:	6.011 Ω	Mobility:	-38.5362 cm ² /(V s)
Resistivity:	0.0001112 Ω cm	Conductivity:	8.99e+3 /(Ω cm)
CCC (Sheet):	-2.694e+16 /cm ²	CCC (bulk):	-1.456e+21 /cm ³
AC cross Hall coefficient:	-0.004281 cm ³ /C	BD cross Hall coefficient:	-0.00429 cm ³ /C
Ratio of Vertical/Horizontal:	0.919626	Average hall coefficient:	-0.004285 cm ³ /C
Magneto-Resistance:	0 Ω		

LINSEIS

Hall effect measurement report

Parameters

Date:	Fri Nov 8 13:06:40 2019
Sample name:	ITO 200
Temperature:	20.09 °C
Res. current:	10 mA
Hall current:	10 mA
Thickness:	0.185 µm

Measurement data

AB [mV]	BC [mV]	AC [mV]	+MAC [mV]	-MAC [mV]
13.16	12.1	-1.061	-1.226	-0.9049
CD [mV]	DA [mV]	BD [mV]	+MBD [mV]	-MBD [mV]
13.16	12.1	1.061	0.9056	1.227

Results

Sheet resistance:	5.721 Ω	Mobility:	-40.6961 cm ² /(V s)
Resistivity:	0.0001058 Ω cm	Conductivity:	9.45e+3 /(Ω cm)
CCC (Sheet):	-2.681e+16 /cm ²	CCC (bulk):	-1.449e+21 /cm ³
AC cross Hall coefficient:	-0.004304 cm ³ /C	BD cross Hall coefficient:	-0.00431 cm ³ /C
Ratio of Vertical/Horizontal:	0.919333	Average hall coefficient:	-0.004307 cm ³ /C
Magneto-Resistance:	0 Ω		

General features

- NIST routine to find optimum measurement settings and get highest accurate results
- Extended connection test
- Possible integration of external electronics
- Optional Database storage
- Optional Lock-in amplifier integration
- Automatic sensor recognition (EEPROM)
- Automatic evaluation
- Fully automatic cooling regulation
- HCS L36 *Ultimate* online access to fit data

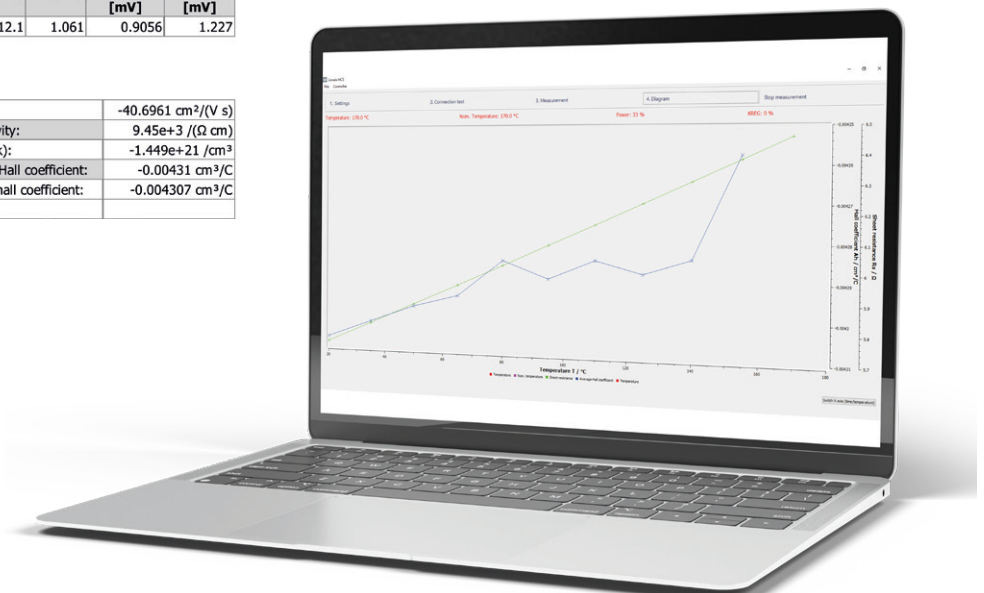

Technical Specifications

	HCS L36 Basic	HCS L36 Advanced	HCS L36 Ultimate
Temperature range	LN2 up to 600 °C in different versions (continuously from LT to HT) -160 °C (controlled cooling) -196 °C (quench cooling)	RT up to 600 C	LN2 up to 600 °C in different versions (continuously from LT to HT) -160 °C (controlled cooling) -196 °C (quench cooling)
Magnet	Permanent magnets up to 0.70 T DC field Pole diameter 120 mm Two magnet setup for bipolar measurement.	Magnet up to 0.5 T (AC or DC field) Multisegment Halbach configuration Inner diameter: 40mm Height: 98mm	Electromagnet with 76 mm of pole diameter. AC power supply for measurements up to 0.1 Hz at up to +-40 A
Current source	DC 1 nA up to 125 mA (8 decades / Compliance +/- 12 V)		
Voltage measurement	DC low noise / low drift 1 μV up to 2500 mV 4 decades amplification Digital resolution: 300 pV	DC low noise / low drift 1μV up to 2500mV 4 decades amplification Digital resolution: 300pV AC 20 nV up to 1V Features: GΩ range input impedance, variable integration times and amplification	
Sensors / Sample geometry	Seebeck Sensor, Illumination Sensor, Gated hall bar from 5 x 5 mm to 12.5 x 12.5 mm Maximum sample height 3 mm from 17.5 x 17.5 mm up to 25 x 25 mm Maximum sample height 5 mm from 42.5 x 42.5 mm up to 50 x 50 mm Maximum sample height 5 mm High Temperature board 10x10 mm, max. sample height 3 mm	up to 12.5 x 12.5mm Maximum sample height 2.0 mm	Seebeck Sensor, Illumination Sensor, Gated hall bar from 5 x 5 mm to 12.5 x 12.5 mm Maximum sample height 3 mm from 17.5 x 17.5 mm up to 25 x 25 mm Maximum sample height 5 mm from 42.5 x 42.5 mm up to 50 x 50 mm Maximum sample height 5 mm High Temperature board 10x10 mm, max. sample height 3 mm
Resistivity Range	10 ⁻⁴ up to 10 ⁷ (Ωcm)	10 ⁻⁵ up to 10 ⁷ (Ωcm)	10 ⁻⁴ up to 10 ⁷ (Ωcm)
Carrier concentration	10 ⁷ up to 10 ²¹ cm ⁻³	10 ⁷ up to 10 ²² cm ⁻³	10 ⁷ up to 10 ²¹ cm ⁻³
Mobility range	0.1 ~ 10 ⁷ cm ² V ⁻¹ s ⁻¹	1 ~ 10 ⁷ cm ² V ⁻¹ s ⁻¹	10 ⁻³ ~ 10 ⁷ cm ² V ⁻¹ s ⁻¹
Atmospheres	Vacuum, inert, oxidizing, reducing	Vacuum, inert, oxidizing, reducing	Vacuum, inert, oxidizing, wvreducing
Temperature resolution	0.001 °C	0.001 °C	0.001 °C

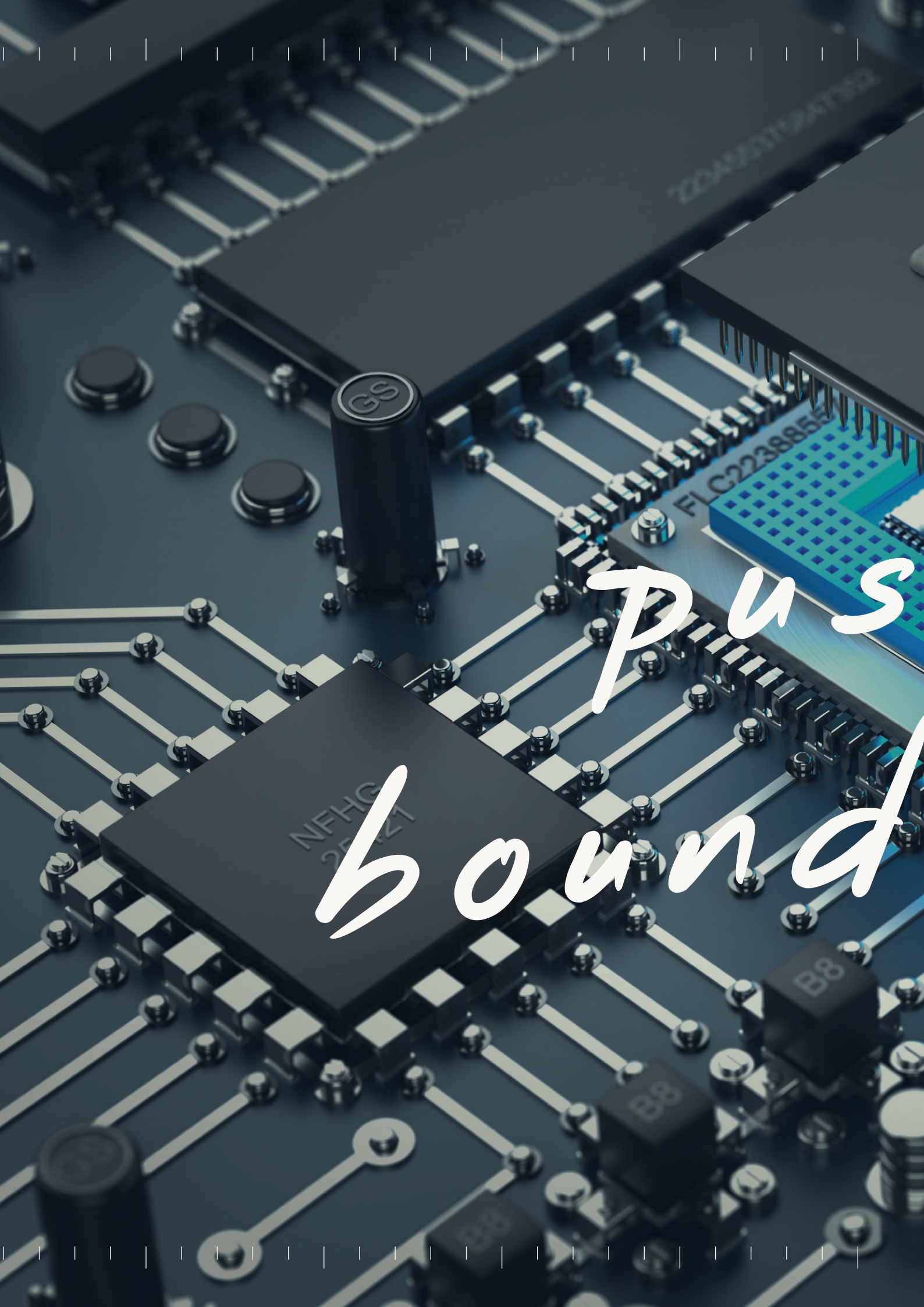

Plus
bound

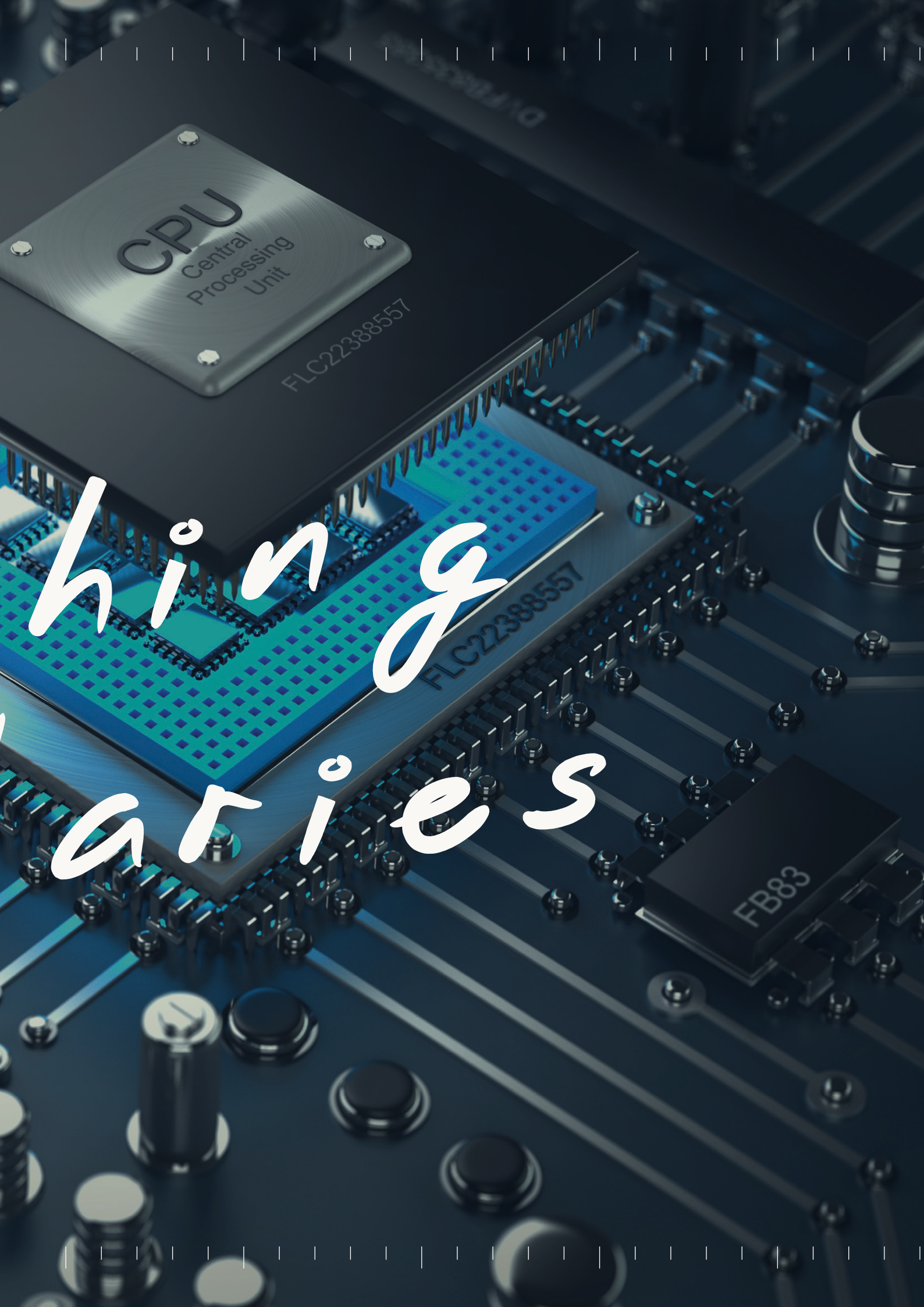

hiring carriers



Applications HCS

Antimony Thin Film (150 nm Sb)

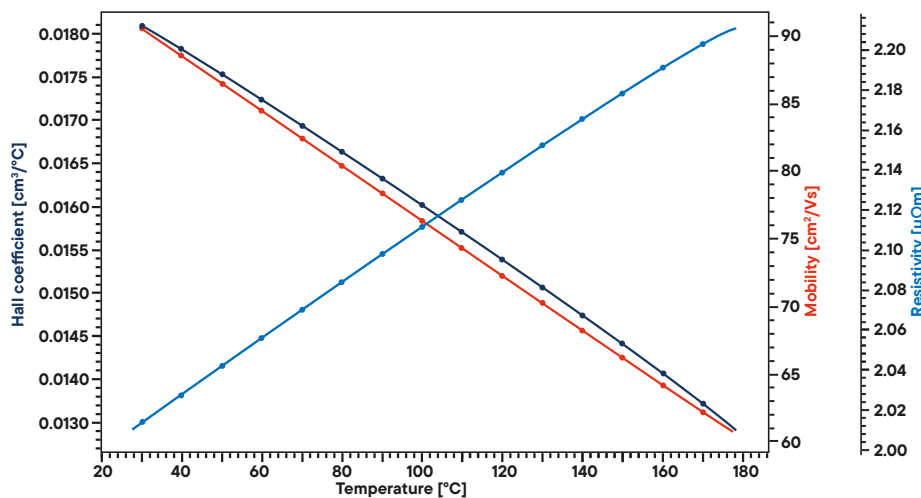

Antimony (Sb) is a semimetal, which is widely used in the field of thermoelectrics (in form of alloys, e.g. Bi_{1-x}Sb_x) and as an emerging application is the field of microelectronics. Nevertheless, the largest applications for metallic antimony are lead antimony plates in leadacid batteries. The figure shows a full characterization of a thin film on SiO₂/Si substrate, prepared by sputter deposition, with the Linseis HCS 1 (RT to 200 °C option).

Bismuth-antimony Thin Film (150 nm Bi₈₇Sb₁₃)

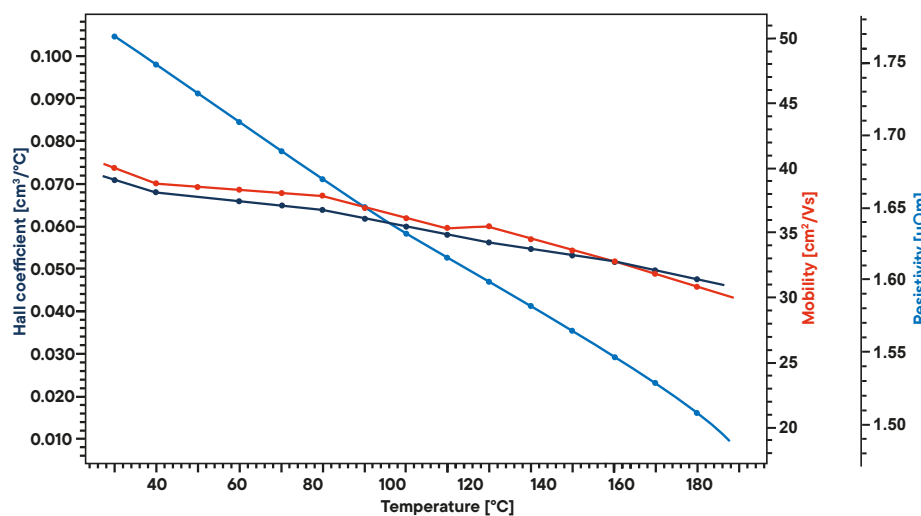

Bismuth-antimony alloys, (Bi_{1-x}Sb_x) are binary alloys of bismuth and antimony in various ratios. Some, in particular Bi_{0.9}Sb_{0.1}, were the first experimentally observed three-dimensional topological insulators, materials that have conducting surface states but have an insulating interior. Various BiSb alloys are also used in low temperature thermoelectric devices. The presented measurement has been conducted on a thermally evaporated Bi₈₇Sb₁₃ thin film.

ITO (Indium tin oxide) up to 600 °C

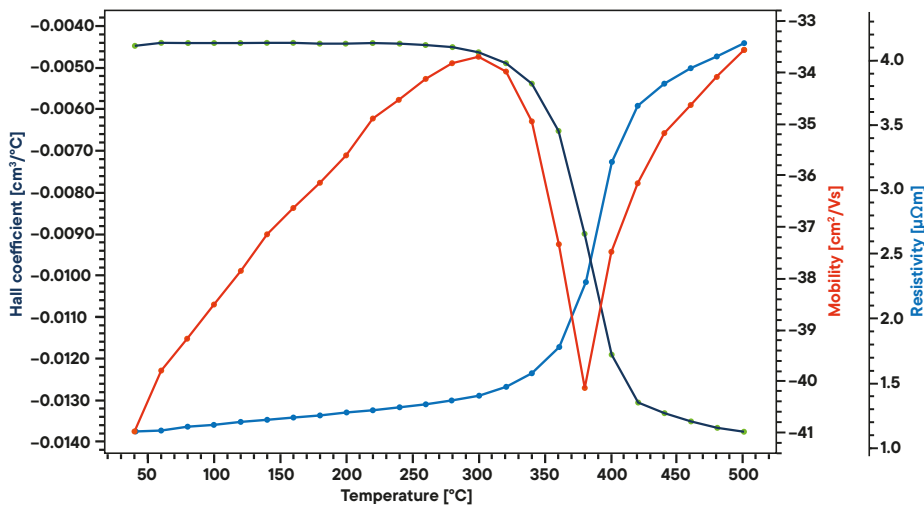

Indium tin oxide (ITO) is a ternary composition of indium, tin and oxygen in varying proportions. Depending on the oxygen content, it can either be described as a ceramic or alloy. It is transparent and colorless in thin layers and is one of the most widely used transparent conducting oxides because of its two main properties: its electrical conductivity and optical transparency. As with all transparent conducting films, a compromise must be made between conductivity and transparency, since increasing the thickness and increasing the concentration of charge carriers increases the material's conductivity, but decreases its transparency.

ITO (Indium tin oxide) up to 200 °C

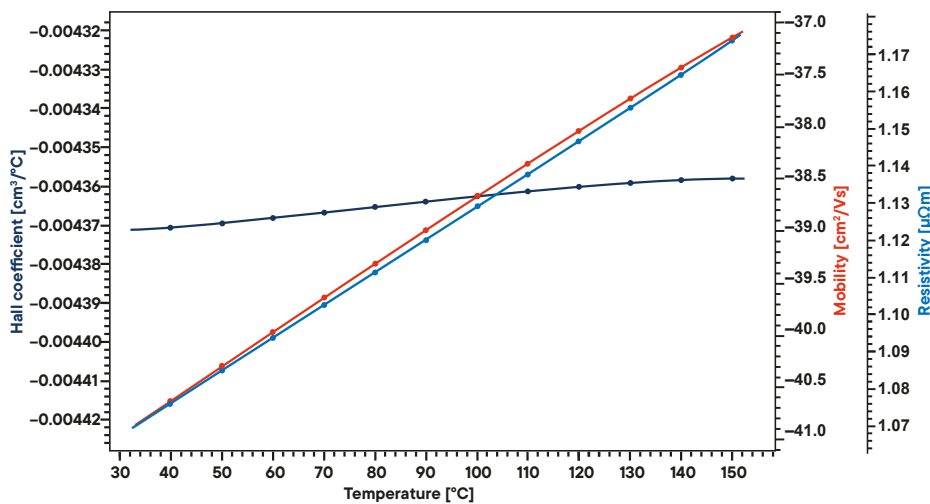

The two diagrams show a full characterization of two different ITO thin films (both 185 nm in thickness), prepared by sputter deposition with the Linseis HCS 1 (RT to 200 °C option) as well as HCS 10 (High temperature option up to +600 °C).



Contract Testing

LINSEIS

pushing boundaries

LINSEIS GmbH Germany

Vielitzerstr. 43
95100 Selb

Tel.: (+49) 9287 880 0
E-mail: info@linseis.de

LINSEIS Inc. USA

109 North Gold Drive
Robbinsville, NJ 08691

Tel.: (+1) 609 223 2070
E-mail: info@linseis.com

LINSEIS China

Kaige Scientific Park
Room 120, Building T3, No.1220
Yuqiao Road, Pudong, Shanghai

Tel.: (+86) 61 90 12 03
Tel.: (+86) 50 55 06 42
E-mail: info@linseis.com.cn

LINSEIS India

Plot 65, 2nd Floor, Sai Enclave,
Sector 23, Dwarka05-800
110077 New Delhi

Tel.: +91-11-42883851
E-mail: sales@linseis.in



WWW.LINSEIS.COM